

Occupational Exposure to Austrian Rocks Used as Radon Spa Sources in Japan

Kazuki Iwaoka^{1*}, Hiroyuki Tabe¹, Tetuo Ishikawa¹,
Shinji Tokonami² and Hidenori Yonehara¹

¹Research Center for Radiation Protection, National Institute of Radiological Sciences, 4-9-1 Anagawa, Inage-ku, Chiba 263-8555 Japan
²Institute of Radiation Emergency Medicine, Hiroasaki University, 66-1 Hon-cho, Hiroasaki, Aomori 036-8564 Japan

Received 2 June 2012; revised 26 August 2012; accepted 4 September 2012

The activity concentrations of natural radionuclides in Austrian rocks used as artificial radon spa sources in Japan as well as the ²²²Rn and ²²⁰Rn concentrations, and the ambient dose rates at work sites in a dealership for the Austrian rocks were measured, and the dose estimation for the worker was conducted. The activity concentrations of ²²⁶Ra, ²²⁸Ra, and ⁴⁰K in the Austrian rocks were found to be less than the critical values in the International Atomic Energy Agency safety guide. The ambient dose rates and ²²²Rn concentrations at the work sites were higher than that in the background. The ²²⁰Rn concentrations in all sites were less than the limit of determination. The value of the total effective dose to the worker was 560 μSv y⁻¹, which was less than the intervention exemption level (1000 μSv y⁻¹) given in the International Commission on Radiological Protection Publication 82.

Key words: NORM, natural radionuclides, radon spa source, occupational exposure

1. Introduction

A material containing significant amounts of natural radionuclides such as ²³⁸U and ²³²Th series is referred to as a naturally occurring radioactive material (NORM). Recently, balls sintered with natural resources containing natural radionuclides in high concentrations and rocks from radon spas in Austria have been commercially available as artificial radon spa sources in Japan. Although the radiological characterization of the sintered balls has

been reported¹⁾, radiological data on the Austrian rocks are rare. If the Austrian rocks contain high concentrations of natural radionuclides, the worker handling them could be unknowingly exposed to high levels of radiation. Therefore, the Austrian rocks need to be characterized to estimate the radiation exposure level of the worker handling them.

In this study, the activity concentrations of natural radionuclides in the Austrian rocks as well as the ²²²Rn and ²²⁰Rn concentrations, and the ambient dose rates at the work sites were measured, and the dose estimation for the worker was conducted.

2. Materials and Methods

2.1. Survey site and sample

A dealership of the Austrian rocks used as radon spa

*Kazuki Iwaoka: Research Center for Radiation Protection, National Institute of Radiological Sciences
4-9-1 Anagawa, Inage-ku, Chiba 263-8555, Japan
E-mail: iwaoka@nirs.go.jp

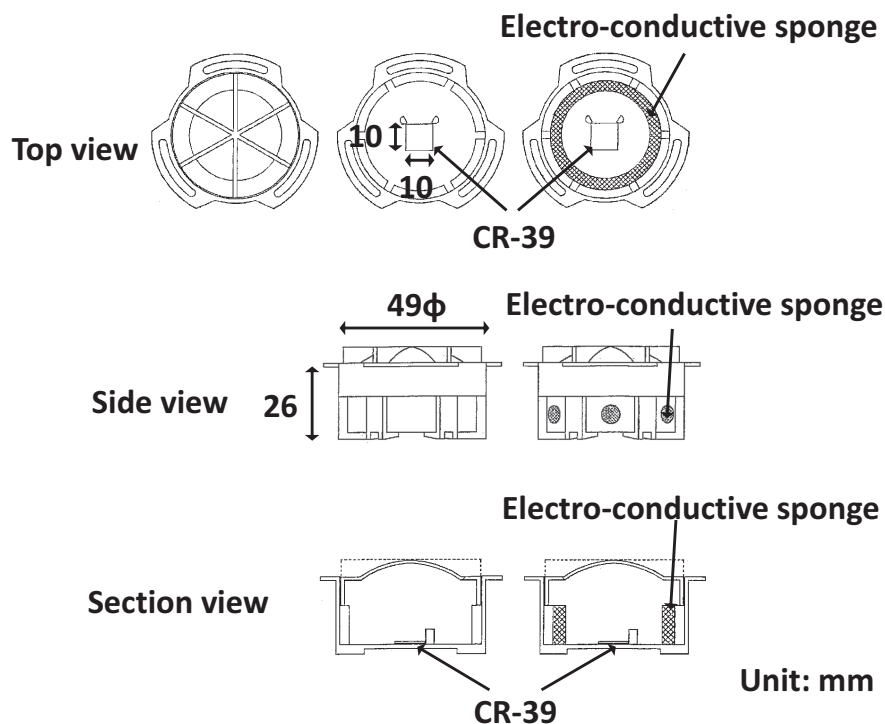

Fig. 1. Overview of the passive ^{222}Rn and ^{220}Rn detector (Raduet)²⁾.

Table 1. Typical annual work hours of the worker at the work sites

Work site	Worker's action	Annual work hours (h y^{-1})
Rock storage	Sorting and packing	310
Desk	Desk work	4700

sources in Japan was chosen for this study. The worker at the dealership routinely sorts and packs suitable rocks, and works at desks. These tasks are conducted in an apartment. The typical annual work hours of the worker on the basis of hearing investigation in the dealership are shown in Table 1. For sample analysis, the Austrian rocks were collected at the dealership. These rocks are raw rocks mined in radon spas in Austria.

2.2. Measurement

2.2.1. Ambient dose rate

A 2''(diameter) \times 2''(thickness) NaI (Tl) scintillation survey meter (Inspector 1000, Canberra Industries Inc.) was used for measuring the ambient dose rates at a height of 1 m from the floor in each work site. Temperature drifts on the survey meter were checked by using a ^{137}Cs source. The average ambient dose rates were determined by averaging 6 measurements of 10 s each.

2.2.2. Activity concentration

The activity concentrations of the ^{238}U and ^{232}Th series, and ^{40}K in the Austrian rocks were determined by gamma

ray spectrum analysis. The Austrian rocks were crushed and dried at 105°C for 24 h. Approximately 100 cm³ of the crushed rocks was sealed in a sample container to prevent leakage of ^{222}Rn . The sealed container sample was stored for four weeks to allow ^{226}Ra and its decay products to reach radioactive equilibrium. The gamma ray spectrum of the sample was measured using a high-purity germanium (HPGe) detector. The activity concentration of the ^{226}Ra (^{238}U series) was determined from the 609.31 keV energy peak of ^{214}Bi by assuming the equilibrium between ^{226}Ra and ^{214}Bi . The activity concentration of ^{228}Ra (^{232}Th series) was determined from the 911.20 keV energy peak of ^{228}Ac by assuming equilibrium between ^{228}Ra and ^{228}Ac . The activity concentration of ^{40}K was determined from the energy peak at 1460.75 keV. Counting times for the samples and background were set at 80000 s and 240000 s, respectively. The background counts were used to correct the net gamma-ray peak areas for the studied isotopes.

2.2.3. ^{222}Rn and ^{220}Rn concentrations

The ^{222}Rn and ^{220}Rn concentrations were measured by using passive ^{222}Rn and ^{220}Rn detectors with CR-39 plates (Raduet; Radosys Co. Ltd.)²⁾. The detectors consists of two chambers (Figure 1). Each chamber is made of an electroconductive plastic and is cylindrical with an inner volume of 30 cm³. The CR-39 plate is placed at the bottom of the chamber with sticky clays. The ^{222}Rn in air can penetrate into the chamber though an airspace between its lid and bottom. Since this airspace functions as the high

diffusion barrier, ^{220}Rn can scarcely go into the chamber due to its so short half-life (55.4 s), compared with that of ^{222}Rn (3.82 d). For the detection of ^{220}Rn , six holes of 6 mm in diameter are opened at the side of the other chamber and covered with an electroconductive sponge. Regarding the detection limits of the detectors, if the ^{220}Rn concentration is assumed to be 100 Bq m^{-3} , the lower detection limit of ^{222}Rn concentration is 3 Bq m^{-3} . If the ^{222}Rn concentration is assumed to be 40 Bq m^{-3} , the lower detection limit of ^{220}Rn concentration is 14 Bq m^{-3} ²⁾

The detectors were placed at each work site which was at a distance of 1 m or more from the surface of the materials, floors, and walls for approximately 6 months. After exposure, the CR-39 plates were removed from the chambers and were chemically etched with a 6.25M NaOH solution at 90°C over 6h, and the alpha tracks were counted. The ^{222}Rn and ^{220}Rn concentrations derived from two alpha track densities of low and high air exchange-rate chamber (NL and NH) were determined by solving Eq. (1) and (2) ²⁾:

$$\text{NL} = C_{\text{Rn}} \times F_{\text{Rn1}} \times T + C_{\text{Th}} \times F_{\text{Th1}} \times T + B \quad (1)$$

$$\text{NH} = C_{\text{Rn}} \times F_{\text{Rn2}} \times T + C_{\text{Th}} \times F_{\text{Th2}} \times T + B \quad (2)$$

where C_{Rn} and C_{Th} are the mean concentrations of ^{222}Rn and ^{220}Rn during the exposure period (Bq m^{-3}), F_{Rn1} and F_{Th1} are the ^{222}Rn and ^{220}Rn conversion factors for the low air-exchange-rate chamber ($\text{tracks cm}^{-2} \text{ kBq}^{-1} \text{ m}^3 \text{ h}^{-1}$), F_{Rn2} and F_{Th2} are the ^{222}Rn and ^{220}Rn conversion factors for the high air-exchange-rate chamber ($\text{tracks cm}^{-2} \text{ kBq}^{-1} \text{ m}^3 \text{ h}^{-1}$), T is the exposure time (h), and B is the blank alpha track density on the CR-39 detector (tracks cm^{-2}).

2.3. Dose estimation

2.3.1. External dose

The dose estimation of the external gamma-radiation exposure of the worker was conducted by using Eq. (3), which was reformed on the basis of equations in the UNSCEAR 2008 report³⁾:

$$E_{\text{EXT}} = (P - P_{\text{BG}}) \times F_e \times T_e \quad (3)$$

where E_{EXT} is the annual effective dose of the external gamma exposure ($\mu\text{Sv y}^{-1}$), and P and P_{BG} are the ambient dose rates at the measurement points and the background site in a similar apartment without the Austrian rocks ($\mu\text{Sv h}^{-1}$), respectively, F_e is the factor for the conversion of the ambient dose into effective dose, and T_e is the annual work hours (h y^{-1}). F_e was assumed to be 0.7 based on the International Atomic Energy Agency (IAEA) technical documentation⁴⁾

2.3.2. Inhalation dose

Although inhalation exposure to ^{222}Rn and dust derived from the subject material is generally considered, the inhalation exposure to the dusts is not expected in this study because there are no dust-producing work tasks. Therefore, the effective dose of the inhalation exposure to

Table 2. Activity concentrations of the Austrian rocks

Material	Origin	Activity concentration (Bq g^{-1})		
		^{238}U series	^{232}Th series	^{40}K
		^{226}Ra	^{228}Ra	
Raw rock	Austria	0.39 ± 0.00	0.27 ± 0.01	1.6 ± 0.0

Uncertainty in the activity concentration is the standard deviation (1σ) based on counting statistics.

^{222}Rn was estimated by using Eq. (4), which was reformed on the basis of equations in the UNSCEAR 2008 report³⁾:

$$E_{\text{INH}} = [D_{\text{RN}} \times (C_{\text{RN}} - C_{\text{RNbg}}) \times F_{\text{RN}}] \times T_e \quad (4)$$

where E_{INH} is the annual effective dose of inhalation exposure to ^{222}Rn ($\mu\text{Sv y}^{-1}$), T_e is the annual work hours (h y^{-1}), D_{RN} is the dose coefficient for inhalation exposure to ^{222}Rn decay products [$\mu\text{Sv (Bq m}^{-3} \text{ h)}^{-1}$], C_{RN} is the ^{222}Rn concentration (Bq m^{-3}), F_{RN} is the equilibrium factor of ^{222}Rn , and C_{RNbg} is the ^{222}Rn concentration with background. D_{RN} and F_{RN} were assumed to be 0.009 and 0.4, respectively, based on the UNSCEAR 2008 report³⁾.

2.3.3. Ingestion dose

Although natural sources such as the rocks in this study mainly contain ^{238}U , ^{232}Th , and ^{40}K , there is no need to consider the ingestion dose of ^{40}K because the potassium concentration in tissues is maintained constant due to homeostasis. The effective doses of ingestion exposure to the ^{238}U and ^{232}Th series radionuclides through hand-induced contamination were estimated by using Eq. (5), which was reformed on the basis of equations in the Radiation Protection 122 publication of the European Commission⁵⁾:

$$E_{\text{ING}} = (D_{\text{ING(U)}} \times A_{\text{(U)}} + D_{\text{ING(Th)}} \times A_{\text{(Th)}}) \times T_e \times R_{\text{ING}} \quad (5)$$

where E_{ING} is the annual effective dose of ingestion exposure to the ^{238}U and ^{232}Th series ($\mu\text{Sv y}^{-1}$), $D_{\text{ING(U)}}$ and $D_{\text{ING(Th)}}$ are the dose coefficients for ingestion exposure to the ^{238}U and ^{232}Th series ($\mu\text{Sv Bq}^{-1}$), $A_{\text{(U)}}$ and $A_{\text{(Th)}}$ are the activity concentrations of the ^{238}U and ^{232}Th series in the sample (Bq g^{-1}), and R_{ING} is the ingestion rate (g h^{-1}). $D_{\text{ING(U)}}$, $D_{\text{ING(Th)}}$, and R_{ING} were assumed to be 2.6, 1.1, and 0.01, respectively, based on the Radiation Protection 122 publication⁵⁾.

3. Results and discussion

The results obtained from the measurements of the activity concentrations in the Austrian rocks are shown in Table 2. The activity concentrations of the ^{226}Ra , ^{228}Ra , and ^{40}K in the Austrian rocks were less than the critical values described in the IAEA safety guide (10 Bq g^{-1} for ^{40}K and 1 Bq g^{-1} for all other radionuclides of natural origin)⁶⁾. The results obtained from the measurements of the ambient dose rates, and ^{222}Rn and ^{220}Rn concentrations are shown in Table 3. The ambient dose rates in the rock storage and

Table 3. Ambient dose rates, and ^{222}Rn and ^{220}Rn concentrations in the work sites

Work site	Worker's action	Measurement point	Ambient dose rate ($\mu\text{Sv h}^{-1}$)	^{222}Rn concentration (Bq m^{-3})	^{220}Rn concentration (Bq m^{-3})
Rock storage	Sorting and packing	1 m from material	0.089	$31 \pm 3^{\text{a}}$	BDL ^b
Desk work	Desk work	Work station	0.055	$28 \pm 3^{\text{a}}$	BDL ^b
Background (similar apartment without the Austrian rocks)	—	Center of the similar apartment	0.036	$5 \pm 1^{\text{a,c}}$	BDL ^{b,c}

a: Uncertainty in ^{222}Rn and ^{220}Rn concentrations is the standard deviation (1σ) of three measurements for alpha tracks.

b: Below the detection limit (BDL).

c: The background for ^{222}Rn and ^{220}Rn was determined by averaging the ^{222}Rn and ^{220}Rn concentrations randomly measured at 4 sites.

Table 4. Annual effective dose to the worker

Exposure pathway	Annual effective dose ($\mu\text{Sv y}^{-1}$)
External	74
Inhalation	420
Ingestion	66
Total	560

desk work sites were 0.089 and 0.055 $\mu\text{Sv h}^{-1}$, respectively, which were higher than that in the background (0.036 $\mu\text{Sv h}^{-1}$). The ^{222}Rn concentrations in the rock storage and desk work sites were 31 and 28 Bq m^{-3} , respectively, which were higher than that in the background (5 Bq m^{-3}). The ^{220}Rn concentrations in all sites were less than the limit of determination. This might be attributed to a long-distance between the detectors and the materials⁷.

In estimating the effective dose to the worker, the activity concentrations of ^{226}Ra and ^{228}Ra in the Austrian rock were used as the activity concentrations of the ^{238}U and ^{232}Th series, respectively. Exposure to ^{220}Rn was not considered in the dose estimation because its concentrations in this study were less than the limit of determination. The effective doses obtained from the measurements are shown in Table 4. The value of the total effective dose to the worker was 560 $\mu\text{Sv y}^{-1}$, which was less than the intervention exemption level (1000 $\mu\text{Sv y}^{-1}$) given in the International Commission on Radiological Protection (ICRP) Publication 82⁸.

4. Conclusion

The activity concentrations of ^{226}Ra , ^{228}Ra , and ^{40}K in the Austrian rocks were found to be less than the critical values in the IAEA Safety Guide. The ambient dose rates and ^{222}Rn concentrations at the work sites were higher than that in the background. The ^{220}Rn concentrations in all sites were less than the limit of determination. The value of the total effective dose to worker was 560 $\mu\text{Sv y}^{-1}$, which was less than the intervention exemption level (1000 $\mu\text{Sv y}^{-1}$) given in the ICRP Publication 82.

References

- Ishikawa T, et al. (2011) Radiological characterization of commercially available "radon spa sources." J. Radioanal Nucl Chem 287: 709-713.
- Tokonami S, et al. (2005) Up to date radon thoron discriminative detector for a large scale survey. Rev Sci Instrum 76: 113505.
- UNSCEAR (2008). Sources and effects of ionizing radiation. UNSCEAR 2008 report.
- IAEA (2000) Generic procedures for assessment and response during a radiological emergency. IAEA-TECDOC-1162.
- EC (2001) Application of the concepts of exemption and clearance to natural radiation sources. Radiation Protection 122 Part II.
- IAEA (2004) Application of the concepts of exclusion, exemption, and clearance, Safety Standard Series No. RS-G-1.7.
- Zhuo W, et al. (2001) Simulation of the concentrations and distributions of indoor radon and thoron. Radiation Protection 93: 357-368.
- ICRP (1999) Protection of the public in situations of prolonged radiation exposure. ICRP Publication 82.